

Disorders of Sodium Balance

David H. Ellison

Sodium is the predominant cation in extracellular fluid (ECF); the volume of ECF is directly proportional to the content of sodium in the body. Disorders of sodium balance, therefore, may be viewed as disorders of ECF volume. The body must maintain ECF volume within acceptable limits to maintain tissue perfusion because plasma volume is directly proportional to ECF volume. The plasma volume is a crucial component of the blood volume that determines rates of organ perfusion. Many authors suggest that ECF volume is maintained within narrow limits despite wide variations in dietary sodium intake. However, ECF volume may increase as much as 18% when dietary sodium intake is increased from very low to moderately high levels [1,2]. Such variation in ECF volume usually is well tolerated and leads to few short-term consequences. In contrast, the same change in dietary sodium intake causes only a 1% change in mean arterial pressure (MAP) in normal persons [3]. The body behaves as if the MAP, rather than the ECF volume, is tightly regulated. Under chronic conditions, the effect of MAP on urinary sodium excretion displays a remarkable gain; an increase in MAP of 1 mm Hg is associated with increases in daily sodium excretion of 200 mmol [4].

Guyton [4] demonstrated the importance of the kidney in control of arterial pressure. Endogenous regulators of vascular tone, hormonal vasoconstrictors, neural inputs, and other nonrenal mechanisms are important participants in short-term pressure homeostasis. Over the long term, blood pressure is controlled by renal volume excretion, which is adjusted to a set point. Increases in arterial pressure lead to natriuresis (called *pressure natriuresis*), which reduces blood volume. A decrease in blood volume reduces venous return to the heart and cardiac output. Urinary volume excretion exceeds dietary intake until the blood volume decreases sufficiently to return the blood pressure to the set point.

Disorders of sodium balance resulting from primary renal sodium retention lead only to modest volume expansion without edema because increases in MAP quickly return sodium excretion to baseline

CHAPTER

2

levels. Examples of these disorders include chronic renal failure and states of mineralocorticoid excess. In this case, the price of a return to sodium balance is hypertension. Disorders of sodium balance that result from secondary renal sodium retention, as in congestive heart failure, lead to more profound volume expansion owing to hypotension. In mild to moderate cases, volume expansion eventually returns the MAP to its set point; the price of sodium balance in this case is edema. In more severe cases, volume expansion never returns blood pressure to normal, and renal sodium retention is unremitting. In still other situations, such as nephrotic syndrome, volume expansion results from changes in both the renal set point and body volume distribution. In this case, the price of sodium balance may be both edema and hypertension. In each of these cases, renal sodium (and chloride) retention results from a discrepancy between the existing MAP and the renal set point.

The examples listed previously emphasize that disorders of sodium balance do not necessarily abrogate the ability to achieve sodium balance. When balance is defined as the equation of sodium intake and output, most patients with ECF expansion (and edema or hypertension) or ECF volume depletion achieve sodium balance. They do so, however, at the expense of expanded or contracted ECF volume. The *failure to achieve sodium balance at normal ECF volumes* characterizes these disorders.

Frequently, distinguishing disorders of sodium balance from disorders of water balance is useful. According to this scheme, disorders of water balance are disorders of body osmolality and usually are manifested by alterations in serum sodium concentration

(see Chapter 1). Disorders of sodium balance are disorders of ECF volume. This construct has a physiologic basis because water balance and sodium balance can be controlled separately and by distinct hormonal systems. It should be emphasized, however, that disorders of sodium balance frequently lead to or are associated with disorders of water balance. This is evident from Figure 2-24 in which hyponatremia is noted to be a sign of either ECF volume expansion or contraction. Thus, the distinction between disorders of sodium and water balance is useful in constructing differential diagnoses; however, the close interrelationships between factors that control sodium and water balance should be kept in mind.

The figures herein describe characteristics of sodium homeostasis in normal persons and also describe several of the regulatory systems that are important participants in controlling renal sodium excretion. Next, mechanisms of sodium transport along the nephron are presented, followed by examples of disorders of sodium balance that illuminate current understanding of their pathophysiology. Recently, rapid progress has been made in unraveling mechanisms of renal volume homeostasis. Most of the hormones that regulate sodium balance have been cloned and sequenced. Intracellular signaling mechanisms responsible for their effects have been characterized. The renal transport proteins that mediate sodium reabsorption also have been cloned and sequenced. The remaining challenges are to integrate this information into models that describe systemic volume homeostasis and to determine how alterations in one or more of the well-characterized systems lead to volume expansion or contraction.

Normal Extracellular Fluid Volume Homeostasis

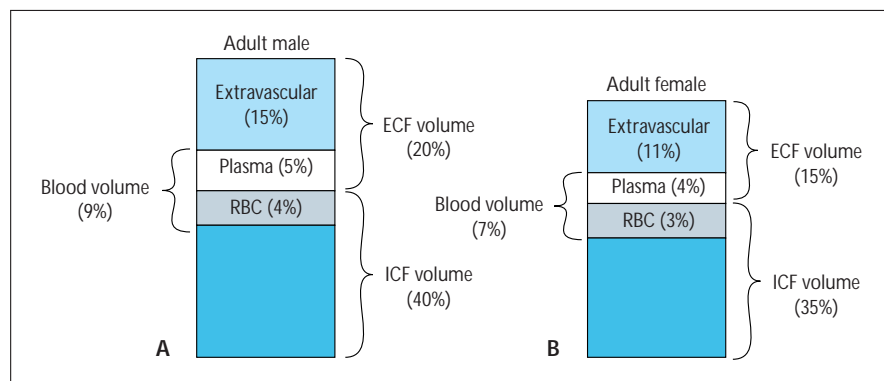
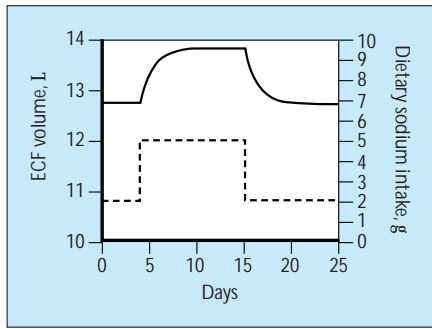

FIGURE 2-1

Fluid volumes in typical adult men and women, given as percentages of body weight. In men (A), total body water typically is 60% of body weight (Total body water = Extracellular fluid [ECF] volume + Intracellular fluid [ICF] volume). The ECF volume comprises the plasma volume and the extravascular volume. The ICF volume comprises the water inside erythrocytes (RBCs) and inside other cells. The blood volume comprises the plasma volume plus the RBC volume. Thus, the RBC volume is a unique component of ICF volume that contributes directly to cardiac output and blood pressure. Typically, water comprises a smaller percentage of the body weight in a woman (B) than in a man; thus, when expressed as a percentage of body weight, fluid volumes are smaller. Note, however, that the percentage of total body water that is intracellular is approximately 70% in both men and women [5].

**FIGURE 2-2**

Effects of changes in dietary sodium (Na) intake on extracellular fluid (ECF) volume. The dietary intake of Na was increased from 2 to 5 g, and then returned to 2 g. The relationship between dietary Na intake (dashed line) and ECF volume (solid line) is derived from the model of Walser [1]. In this model the rate of Na excretion is assumed to be proportional to the content of Na in the body (A_t) above a zero point (A_0) at which Na excretion ceases. This relation can be expressed as $dA_t/dt = I - k(A_t - A_0)$, where I is the dietary Na intake and t is time. The ECF volume is approximated as the total body Na content divided by the plasma Na concentration. (This assumption is strictly incorrect because approximately 25% of Na is tightly bound in bone; however, this amount is nearly invariant and can be ignored in the current analysis.) According to this construct, when dietary Na intake changes from level 1 to level 2, the ECF volume approaches a new steady state exponentially with a time constant of k according to the following equation:

$$A_2 - A_1 = \frac{I_2}{k} + \frac{I_1 - I_2}{k} e^{-kt}$$

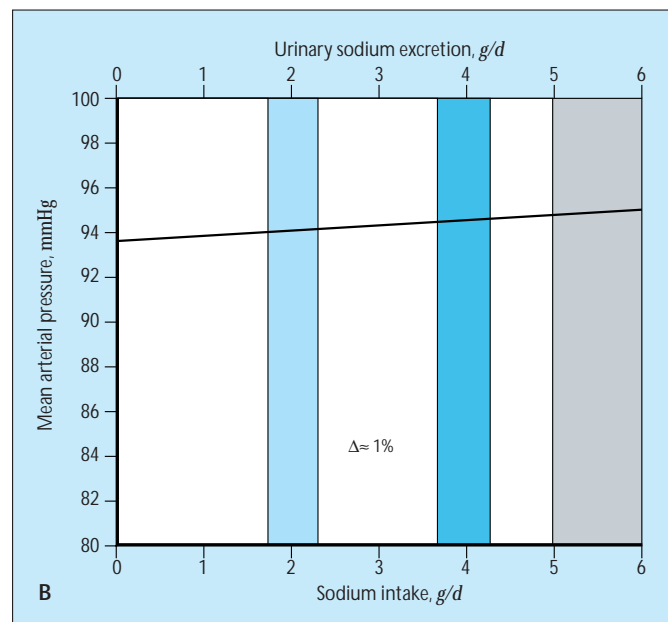
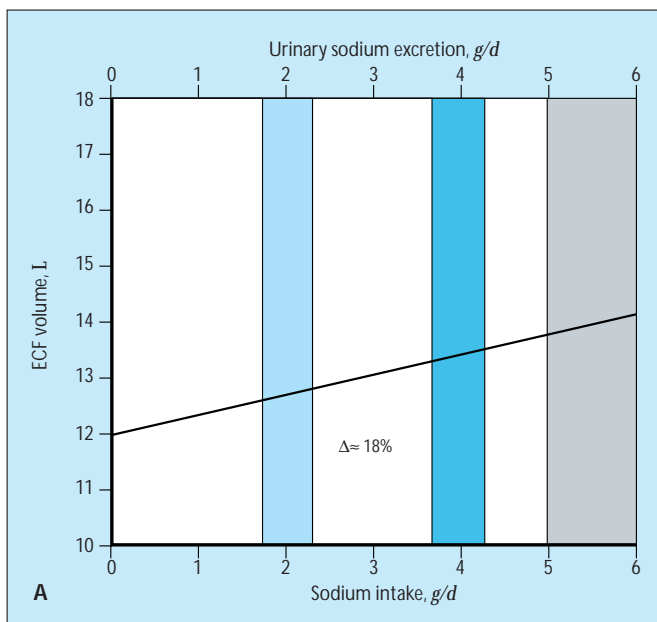
**FIGURE 2-3**

Relation between dietary sodium (Na), extracellular fluid (ECF) volume, and mean arterial pressure (MAP). **A**, Relation between the dietary intake of Na, ECF volume, and urinary Na excretion at steady state in a normal person. Note that 1 g of Na equals 43 mmol (43 mEq) of Na. At steady state, urinary Na excretion essentially is identical to the dietary intake of Na. As discussed in Figure 2-2, ECF volume increases linearly as the dietary intake of Na increases. At an ECF volume of under about 12 L, urinary Na excretion ceases. The gray bar indicates a normal dietary intake of Na when consuming a typical Western diet. The dark blue bar indicates the range of Na

intake when consuming a “no added salt” diet. The light blue bar indicates that a “low-salt” diet generally contains about 2 g/d of Na. Note that increasing the dietary intake of Na from very low to normal levels leads to an 18% increase in ECF volume. **B**, Relation between the dietary intake of Na and MAP in normal persons. MAP is linearly dependent on Na intake; however, increasing dietary Na intake from very low to normal levels increases the MAP by only 1%. Thus, arterial pressure is regulated much more tightly than is ECF volume. (**A**, Data from Walser [1]; **B**, Data from Luft and coworkers [3].)

Mechanisms of Extracellular Fluid Volume Control

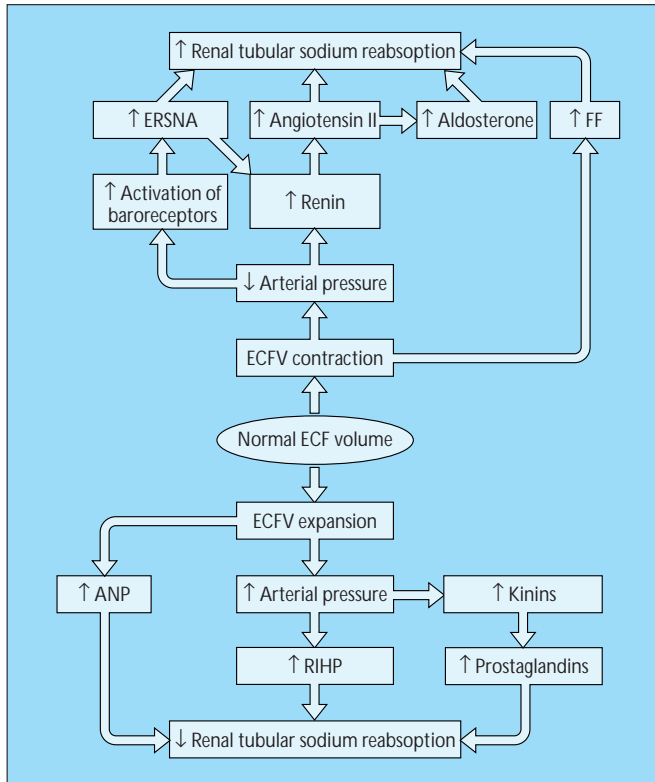

FIGURE 2-6

Integrated response of the kidneys to changes in extracellular fluid (ECF) volume. This composite figure illustrates natriuretic and antinatriuretic mechanisms. For simplicity, the systems are shown operating only in one direction and not all pathways are shown. The major antinatriuretic systems are the renin-angiotensin-aldosterone axis and increased efferent renal sympathetic nerve activity (ERSNA). The most important natriuretic mechanism is pressure natriuresis, because the level of renal perfusion pressure (RPP) determines the magnitude of the response to all other natriuretic systems. Renal interstitial hydrostatic pressure (RIHP) is a link between the circulation and renal tubular sodium reabsorption. Atrial natriuretic peptide (ANP) is the major systemic natriuretic hormone. Within the kidney, kinins and renomedullary prostaglandins are important modulators of the natriuretic response of the kidney. AVP—arginine vasopressin; FF—filtration fraction. (Modified from Gonzalez-Campoy and Knox [7].)

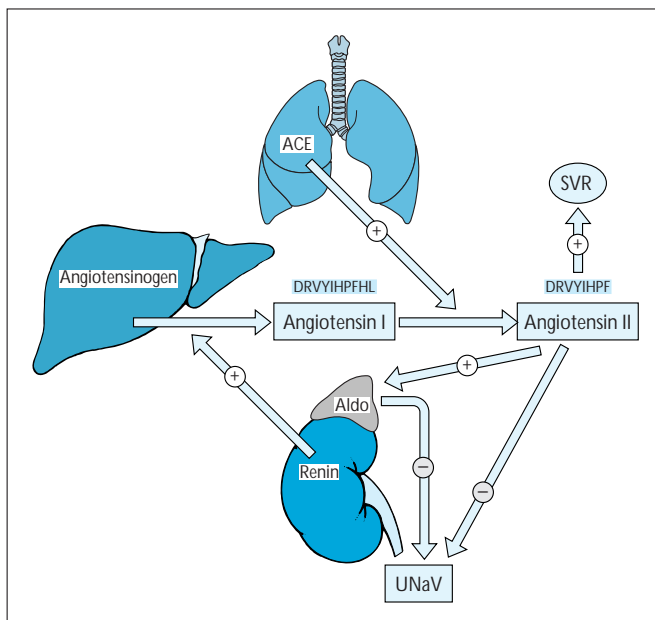
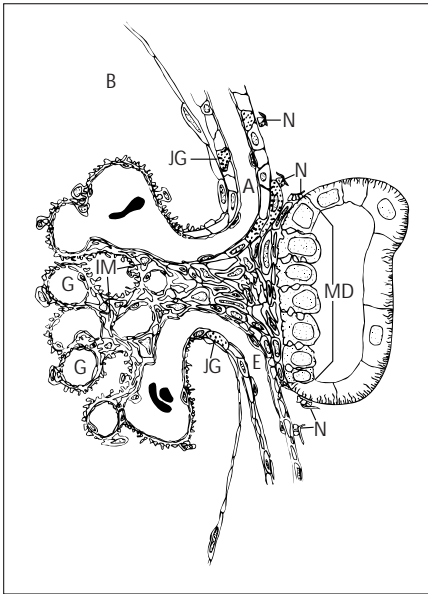
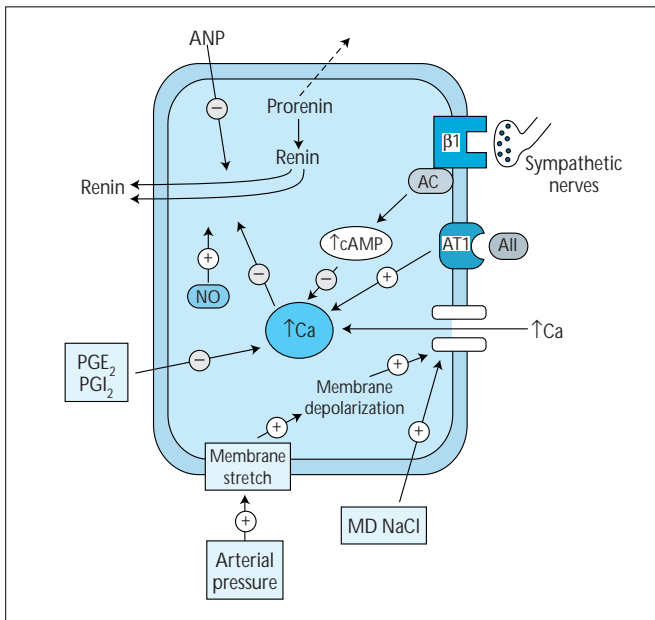

FIGURE 2-7

Overview of the renin-angiotensin-aldosterone system [8,9]. Angiotensinogen (or renin substrate) is a 56-kD glycoprotein produced and secreted by the liver. Renin is produced by the juxtaglomerular apparatus of the kidney, as shown in Figures 2-8 and 2-9. Renin cleaves the 10 N-terminal amino acids from angiotensinogen. This decapeptide (angiotensin I) is cleaved by angiotensin converting enzyme (ACE). The resulting angiotensin II comprises the 8 N-terminal amino acids of angiotensin I. The primary amino acid structures of angiotensins I and II are shown in single letter codes. Angiotensin II increases systemic vascular resistance (SVR), stimulates aldosterone secretion from the adrenal gland (indicated in gray), and increases sodium (Na) absorption by renal tubules, as shown in Figures 2-15 and 2-17. These effects decrease urinary Na (and chloride excretion; U_{NaV}).

**FIGURE 2-8**

The juxtaglomerular (JG) apparatus. This apparatus brings into close apposition the afferent (A) and efferent (E) arterioles with the macula densa (MD), a specialized region of the thick ascending limb (TAL). The extraglomerular mesangium (EM), or lacis “Goormaghtigh apparatus (cells),” forms at the interface of these components. MD cells express the Na-K-2Cl (sodium-potassium-chloride) cotransporter (NKCC2) at the apical membrane [10,11]. By way of the action of this transporter, MD cells sense the sodium chloride concentration of luminal fluid. By way of mechanisms that are unclear, this message is communicated to JG cells located in and near the arterioles (especially the afferent arteriole). These JG cells increase renin secretion when the NaCl concentration in the lumen is low [12]. Cells in the afferent arteriole also sense vascular pressure directly, by way of the mechanisms discussed in Figure 2-9. Both the vascular and tubular components are innervated by sympathetic nerves (N). B—Bowman’s space, G—glomerular capillary; IM—intraglomerular mesangium. (From Barajas [13]; with permission.)

**FIGURE 2-9**

Schematic view of a (granular) juxtaglomerular cell showing secretion mechanisms of renin [8]. Renin is generated from prorenin. Renin secretion is inhibited by increases in and stimulated by decreases in intracellular calcium (Ca) concentrations. Voltage-sensitive Ca channels in the plasma membrane are activated by membrane stretch, which correlates with arterial pressure and is assumed to mediate baroreceptor-sensitive renin secretion. Renin secretion is also stimulated when the concentration of sodium (Na) and chloride (Cl) at the macula densa (MD) decreases [12,14]. The mediators of this effect are less well characterized; however, some studies suggest that the effect of Na and Cl in the lumen is more potent than is the baroreceptor mechanism [15]. Many other factors affect rates of renin release and contribute to the physiologic regulation of renin. Renal nerves, by way of β receptors coupled to adenylyl cyclase (AC), stimulate renin release by increasing the production of cyclic adenosine monophosphate (cAMP), which reduces Ca release. Angiotensin II (AII) receptors (AT1 receptors) inhibit renin release, as least in vitro. Prostaglandins E_2 and I_2 (PGE_2 and PGI_2 , respectively) strongly stimulate renin release through mechanisms that remain unclear. Atrial natriuretic peptide (ANP) strongly inhibits renin secretion. Constitutive nitric oxide (NO) synthase is expressed by macula densa (MD) cells [16]. NO appears to stimulate renin secretion, an effect that may counteract inhibition of the renin gene by AII [17,18].

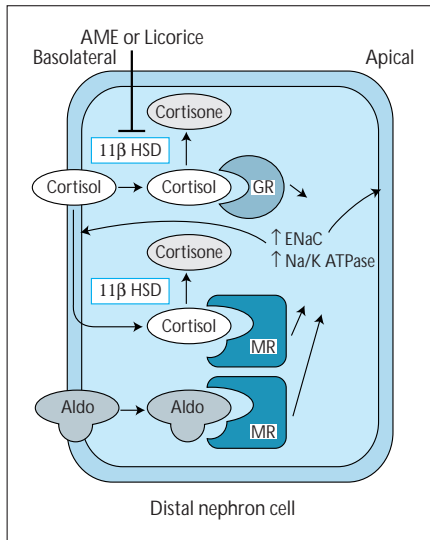

FIGURE 2-10

Mechanism of aldosterone action in the distal nephron [19]. Aldosterone, the predominant human mineralocorticoid hormone, enters distal nephron cells through the plasma membrane and interacts with its receptor (the mineralocorticoid receptor [MR], or Type I receptor). Interaction between aldosterone and this receptor initiates induction of new proteins that, by way of mechanisms that remain unclear, increase the number of sodium channels (ENaC) and sodium-potassium adenosine triphosphatase (Na-K ATPase) pumps at the cell surface. This increases transepithelial Na (and potassium) transport. Cortisol, the predominant human glucocorticoid hormone, also enters cells through the plasma membrane and interacts with its receptor (the glucocorticoid receptor [GR]). Cortisol, however, also interacts with mineralocorticoid receptors; the affinity of cortisol and aldosterone for mineralocorticoid receptors is approximately equal. In distal nephron cells, this interaction also stimulates electrogenic Na transport [20]. Cortisol normally circulates at concentrations 100 to 1000 times higher than the circulating concentration of aldosterone. In aldosterone-responsive tissues, such as the distal nephron, expression of the enzyme 11 β -hydroxysteroid dehydrogenase (11 β -HSD) permits rapid metabolism of cortisol so that only aldosterone can stimulate Na transport in these cells. An inherited deficiency of the enzyme 11 β -HSD (the syndrome of apparent mineralocorticoid excess, AME), or inhibition of the enzyme by ingestion of licorice, leads to hypertension owing to chronic stimulation of distal Na transport by endogenous glucocorticoids [21].

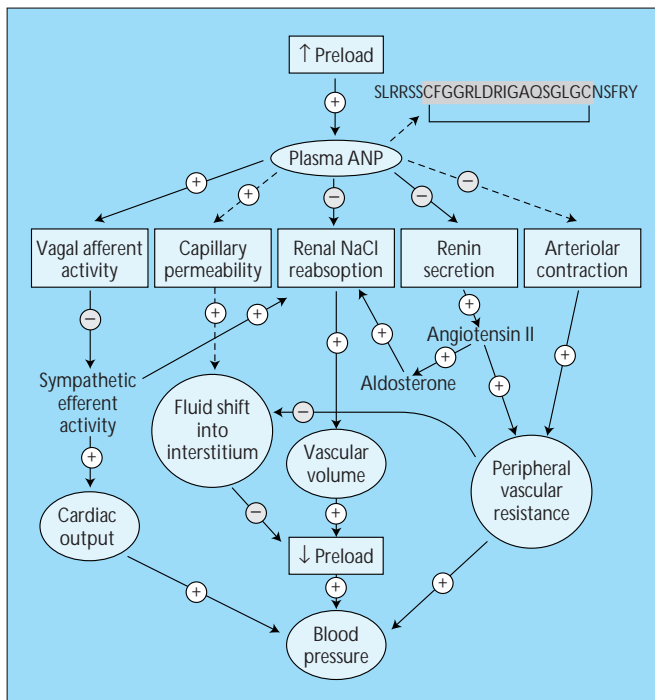

FIGURE 2-11

Control of systemic hemodynamics by the atrial natriuretic peptide (ANP) system. Increases in atrial stretch (PRELOAD) increase ANP secretion by cardiac atria. The primary amino acid sequence of ANP is shown in single letter code with its disulfide bond indicated by the lines. The amino acids highlighted in blue are conserved between ANP, brain natriuretic peptide, and C-type natriuretic peptide. ANP has diverse functions that include but are not limited to the following: stimulating vagal afferent activity, increasing capillary permeability, inhibiting renal sodium (Na) and water reabsorption, inhibiting renin release, and inhibiting arteriolar contraction. These effects reduce sympathetic nervous activity, reduce angiotensin II generation, reduce aldosterone secretion, reduce total peripheral resistance, and shift fluid out of the vasculature into the interstitium. The net effect of these actions is to decrease cardiac output, vascular volume, and peripheral resistance, thereby returning preload toward baseline. Many effects of ANP (indicated by solid arrows) are diminished in patients with edematous disorders (there is an apparent resistance to ANP). Effects indicated by dashed arrows may not be diminished in edematous disorders; these effects contribute to shifting fluid from vascular to extravascular tissue, leading to edema. This observation may help explain the association between elevated right-sided filling pressures and the tendency for Na retention [22]. (Modified from Brenner and coworkers [23].)

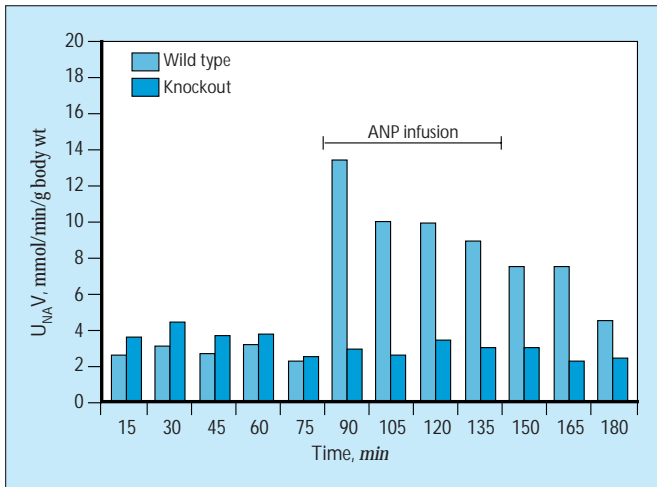

FIGURE 2-12

Mechanism of atrial natriuretic peptide (ANP) action on the kidney. Animals with disruption of the particulate form of guanylyl cyclase (GC) manifest increased mean arterial pressure that is independent of dietary intake of sodium chloride. To test whether ANP mediates its renal effects by way of the action of GC, ANP was infused into wild-type and GC-A-deficient mice. In wild-type animals, ANP led to prompt natriuresis. In GC-A-deficient mice, no effect was observed. $U_{Na}V$ —urinary sodium excretion volume. (Modified from Kishimoto [24].)

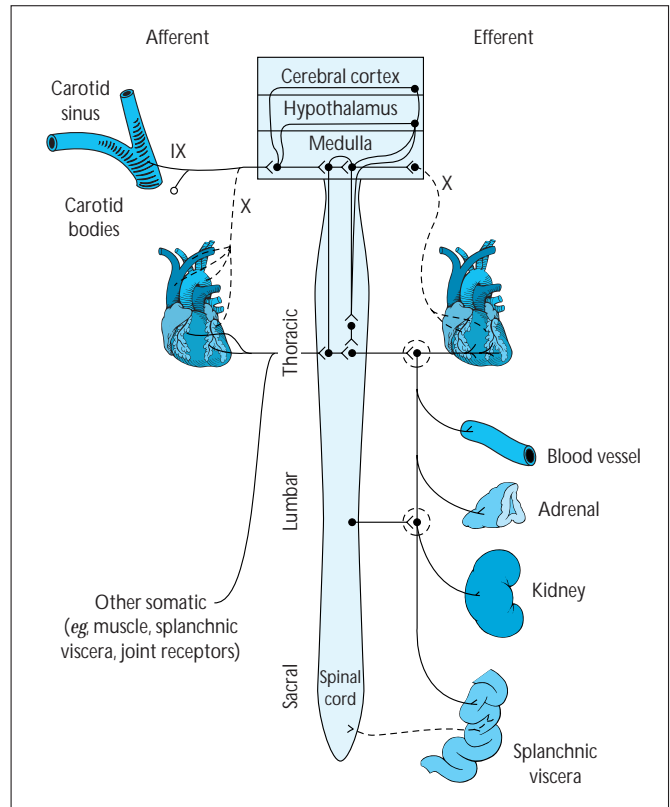

FIGURE 2-13

Schematic diagram of neural connections important in circulatory control. Although the system is bilaterally symmetric, afferent fibers are shown to the left and efferent fibers to the right. Sympathetic fibers are shown as solid lines and parasympathetic fibers as dashed lines. The heart receives both sympathetic and parasympathetic innervation. Sympathetic fibers lead to vasoconstriction and renal sodium chloride retention. X indicates the vagus nerve; IX indicates glossopharyngeal. (From Korner [25]; with permission.)

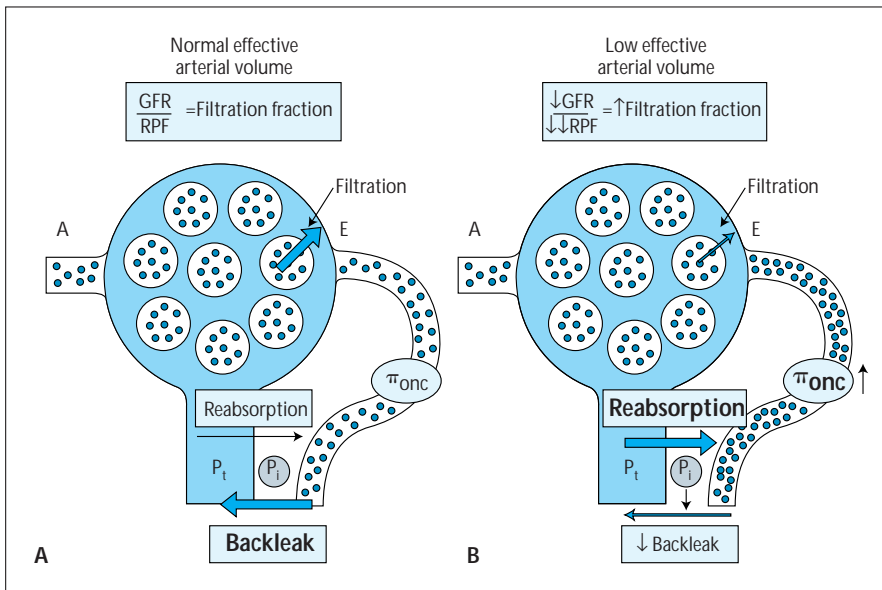

FIGURE 2-14

Cellular mechanisms of increased solute and water reabsorption by the proximal tubule in patients with “effective” arterial volume depletion. **A**, Normal effective arterial volume in normal persons. **B**, Low effective arterial volume in patients with both decreased glomerular filtration rates (GFR) and renal plasma flow (RPF). In contrast to normal persons, patients with low effective arterial volume have decreased GFR and RPF, yet the filtration fraction is increased because the RPF decreases more than does the GFR. The increased filtration fraction concentrates the plasma protein (indicated by the dots) in the peritubular capillaries leading to increased plasma oncotic pressure (π_{onc}). Increased plasma oncotic pressure reduces the amount of backleak from the peritubular capillaries. Simultaneously, the increase in filtration fraction reduces volume delivery to the

(Legend continued on next page)

FIGURE 2-14 (continued)

peritubular capillary, decreasing its hydrostatic pressure, and thereby reducing the renal interstitial hydrostatic pressure (P_i). Even though the proximal tubule hydrostatic pressure (P_t) may be

reduced, owing to diminished GFR, the hydrostatic gradient from tubule to interstitium is increased, favoring increased volume reabsorption. A—afferent arteriole; E—efferent arteriole.

Mechanisms of Sodium and Chloride Transport along the Nephron

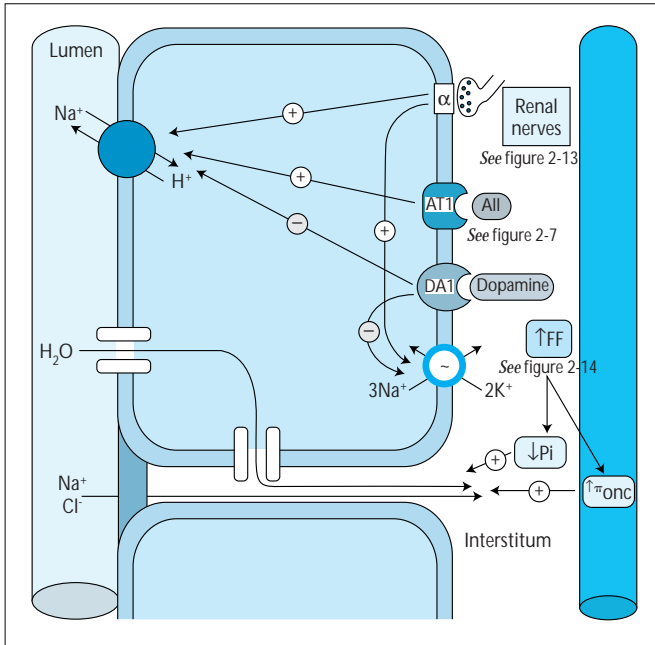
**FIGURE 2-15**

Cellular mechanisms and regulation of sodium chloride (NaCl) and volume reabsorption along the proximal tubule. The sodium-potassium adenosine triphosphate (Na-K ATPase) pump (shown as white circle with light blue outline) at the basolateral cell membrane keeps the intracellular Na concentration low; the K concentration high; and the cell membrane voltage oriented with the cell interior negative, relative to the exterior. Many pathways participate in Na entry across the luminal membrane. Only the sodium-hydrogen (Na-H) exchanger is shown because its regulation in states of volume excess and depletion has been characterized extensively. Activity of the Na-H exchanger is increased by stimulation of renal nerves, acting by way of α receptors and by increased levels of circulating angiotensin II (AII), as shown in Figures 2-7 and 2-13 [25–28]. Increased levels of dopamine (DA1) act to inhibit activity of the Na-H exchanger [29,30]. Dopamine also acts to inhibit activity of the Na-K ATPase pump at the basolateral cell membrane [30]. As described in Figure 2-14, increases in the filtration fraction (FF) lead to increases in oncotic pressure (π_{onc}) in peritubular capillaries and decreases in peritubular and interstitial hydrostatic pressure (P_i). These changes increase solute and volume absorption and decrease solute backflux. Water flows through water channels (Aquaporin-1) Na and Cl also traverse the paracellular pathway.

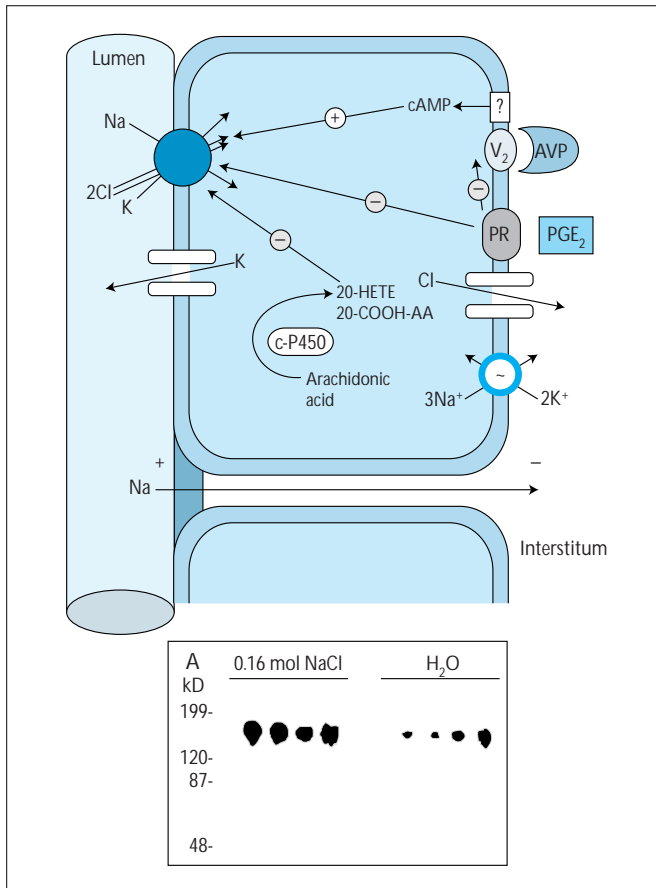

FIGURE 2-16

Cellular mechanisms and regulation of sodium (Na) and chloride (Cl) transport by thick ascending limb (TAL) cells. Na, Cl, and potassium (K) enter cells by way of the bumetanide-sensitive Na-K-2Cl cotransporter (NKCC2) at the apical membrane. K recycles back through apical membrane K channels (ROMK) to permit continued operation of the transporter. In this nephron segment, the asymmetric operations of the luminal K channel and the basolateral chloride channel generate a transepithelial voltage, oriented with the lumen positive. This voltage drives paracellular Na absorption. Although arginine vasopressin (AVP) is known to stimulate Na reabsorption by TAL cells in some species, data from studies in human subjects suggest AVP has minimal or no effect [31,32]. The effect of AVP is mediated by way of production of cyclic adenosine monophosphate (cAMP). Prostaglandin E_2 (PGE_2) and cytochrome P450 (c-P450) metabolites of arachidonic acid (20-HETE [hydroxy-eicosatetraenoic acid] and 20-COOH-AA) inhibit transepithelial NaCl transport, at least in part by inhibiting the Na-K-2Cl cotransporter [33–35]. PGE_2 also inhibits vasopressin-stimulated Na transport, in part by activating G_i and inhibiting adenylyl cyclase [36]. Increases in medullary NaCl concentration may activate transepithelial Na transport by increasing production of PGE_2 . **Inset A.** Regulation of NKCC2 by chronic Na delivery. Animals were treated with 0.16 mol NaCl or water as drinking fluid for 2 weeks. The Western blot shows upregulation of NKCC2 in the group treated with saline [37]. G_i —inhibitory G protein; PR—prostaglandin receptor; V_2 —AVP receptors. (Modified from Ecelbarger [37].)

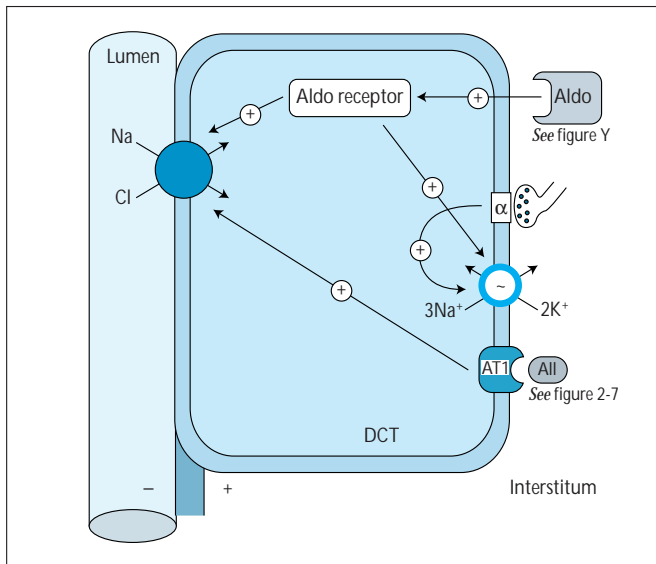

FIGURE 2-17

Mechanisms and regulation of sodium (Na) and chloride (Cl) transport by the distal nephron. As in other nephron segments, intracellular Na concentration is maintained low by the action of the Na-K ATPase (sodium-potassium adenosine triphosphatase) pump at the basolateral cell membrane. Na enters distal convoluted tubule (DCT) cells across the luminal membrane coupled directly to chloride by way of the thiazide-sensitive Na-Cl cotransporter. Activity of the Na-Cl cotransporter appears to be stimulated by both aldosterone and angiotensin II (AII) [38–40]. Transepithelial Na transport in this segment is also stimulated by sympathetic nerves acting by way of α receptors [41,42]. The DCT is impermeable to water.

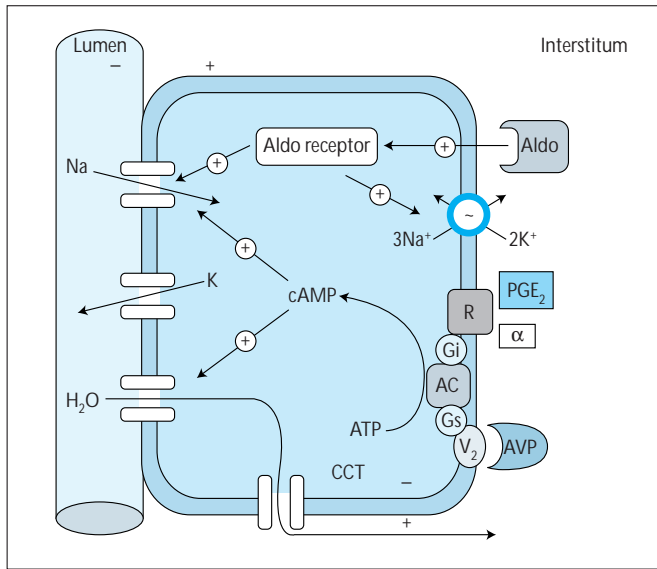

FIGURE 2-18

Principal cortical collecting tubule (CCT) cells. In these cells, sodium (Na) enters across the luminal membrane through Na channels (ENaC). The movement of cationic Na from lumen to cell depolarizes the luminal membrane, generating a transepithelial electrical gradient oriented with the lumen negative with respect to interstitium. This electrical gradient permits cationic potassium (K) to diffuse preferentially from cell to lumen through K channels (ROMK). Na transport is stimulated when aldosterone interacts with its intracellular receptor [43]. This effect involves both increases in the number of Na channels at the luminal membrane and increases in the number of Na-K ATPase (Sodium-potassium adenosine triphosphatase) pumps at the basolateral cell membrane. Arginine vasopressin (AVP) stimulates both Na absorption (by interacting with V_2 receptors and, perhaps, V_1 receptors) and water transport (by interacting with V_2 receptors) [44–46]. V_2 receptor stimulation leads to insertion of water channels (aquaporin 2) into the luminal membrane [47]. V_2 receptor stimulation is modified by PGE_2 and α_2 agonists that interact with a receptor that stimulates G_i [48]. AC—adenylyl cyclase; ATP—adenosine triphosphate; cAMP—cyclic adenosine monophosphate; CCT—cortical collecting tubule; G_i —inhibitory G protein; G_s —stimulatory G protein; R— R_i receptor.

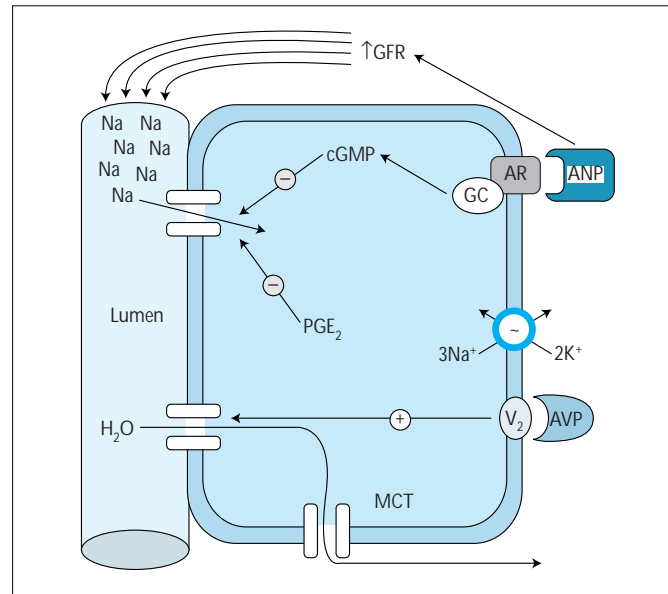

FIGURE 2-19

Cellular mechanism of the medullary collecting tubule (MCT). Sodium (Na) and water are reabsorbed along the MCT. Atrial natriuretic peptide (ANP) is the best-characterized hormone that affects Na absorption along this segment [22]. Data on the effects of arginine vasopressin (AVP) and aldosterone are not as consistent [46,49]. Prostaglandin E_2 (PGE_2) inhibits Na transport by inner medullary collecting duct cells and may be an important intracellular mediator for the actions of endothelin and interleukin-1 [50,51]. ANP inhibits medullary Na transport by interacting with a G-protein-coupled receptor that generates cyclic guanosine monophosphate (cGMP). This second messenger inhibits a luminal Na channel that is distinct from the Na channel expressed by the principal cells of the cortical collecting tubule, as shown in Figure 2-18 [52,53]. Under normal circumstances, ANP also increases the glomerular filtration rate (GFR) and inhibits Na transport by way of the effects on the renin-angiotensin-aldosterone axis, as shown in Figures 2-7 to 2-10. These effects increase Na delivery to the MCT. The combination of increased distal Na delivery and inhibited distal reabsorption leads to natriuresis. In patients with congestive heart failure, distal Na delivery remains depressed despite high levels of circulating ANP. Thus, inhibition of apical Na entry does not lead to natriuresis, despite high levels of MCT cGMP. AR—ANP receptor; GC—guanylyl cyclase; K—potassium; V_2 —receptors.

Causes, Signs, and Symptoms of Extracellular Fluid Volume Expansion and Contraction

CAUSES OF VOLUME EXPANSION

Primary renal sodium retention (with hypertension but without edema)

- Hyperaldosteronism (Conn's syndrome)
- Cushing's syndrome
- Inherited hypertension (Liddle's syndrome, glucocorticoid remediable hyperaldosteronism, pseudohypoaldosteronism Type II, others)
- Renal failure
- Nephrotic syndrome (mixed disorder)

Secondary renal sodium retention

- Hypoproteinemia
- Nephrotic syndrome
- Protein-losing enteropathy
- Cirrhosis with ascites

Low cardiac output

- Hemodynamically significant pericardial effusion
- Constrictive pericarditis
- Valvular heart disease with congestive heart failure
- Severe pulmonary disease
- Cardiomyopathies

Peripheral vasodilation

- Pregnancy
- Gram-negative sepsis
- Anaphylaxis
- Arteriovenous fistula
- Trauma
- Cirrhosis
- Idiopathic edema (?)
- Drugs: minoxidil, diazoxide, calcium channel blockers (?)

Increased capillary permeability

- Idiopathic edema (?)
- Burns
- Allergic reactions, including certain forms of angioedema
- Adult respiratory distress syndrome
- Interleukin-2 therapy
- Malignant ascites

Sequestration of fluid ("3rd spacing," urine sodium concentration low)

- Peritonitis
- Pancreatitis
- Small bowel obstruction
- Rhabdomyolysis, crush injury
- Bleeding into tissues
- Venous occlusion

FIGURE 2-20

In volume expansion, total body sodium (Na) content is increased. In primary renal Na retention, volume expansion is modest and edema does not develop because blood pressure increases until Na excretion matches intake. In secondary Na retention, blood pressure may not increase sufficiently to increase urinary Na excretion until edema develops.

CAUSES OF VOLUME DEPLETION

Extrarenal losses (urine sodium concentration low)

- Gastrointestinal salt losses
 - Vomiting
 - Diarrhea
 - Nasogastric or small bowel aspiration
 - Intestinal fistulae or ostomies
 - Gastrointestinal bleeding
- Skin and respiratory tract losses
 - Burns
 - Heat exposure
 - Adrenal insufficiency
 - Extensive dermatologic lesions
 - Cystic fibrosis
 - Pulmonary bronchorrhea
 - Drainage of large pleural effusion

Renal losses (urine sodium concentration normal or elevated)

- Extrinsic
 - Solute diuresis (glucose, bicarbonate, urea, mannitol, dextran, contrast dye)
 - Diuretic agents
 - Adrenal insufficiency
 - Selective aldosterone deficiency
- Intrinsic
 - Diuretic phase of oliguric acute renal failure
 - Postobstructive diuresis
 - Nonoliguric acute renal failure
 - Salt-wasting nephropathy
 - Medullary cystic disease
 - Tubulointerstitial disease
 - Nephrocalcinosis

FIGURE 2-21

In volume depletion, total body sodium is decreased.

CLINICAL SIGNS OF VOLUME EXPANSION

Edema
Pulmonary crackles
Ascites
Jugular venous distention
Hepatjugular reflux
Hypertension

FIGURE 2-22

Clinical signs of volume expansion.

CLINICAL SIGNS OF VOLUME DEPLETION

Orthostatic decrease in blood pressure and increase in pulse rate
Decreased pulse volume
Decreased venous pressure
Loss of axillary sweating
Decreased skin turgor
Dry mucous membranes

FIGURE 2-23

Clinical signs of volume depletion.

LABORATORY SIGNS OF VOLUME DEPLETION OR EXPANSION

Hypernatremia
Hyponatremia
Acid-base disturbances
Abnormal plasma potassium
Decrease in glomerular filtration rate
Elevated blood urea nitrogen–creatinine ratio
Low functional excretion of sodium (FE_{Na})

FIGURE 2-24

Note that laboratory test results for volume expansion and contraction are similar. Serum sodium (Na) concentration may be increased or decreased in either volume expansion or contraction, depending on the cause and intake of free water (see Chapter 1). Acid-base disturbances, such as metabolic alkalosis, and hypokalemia are common in both conditions. The similarity of the laboratory test results of volume depletion and expansion results from the fact that the “effective” arterial volume is depleted in both states despite dramatic expansion of the extracellular fluid volume in one.

Unifying Hypothesis of Renal Sodium Excretion

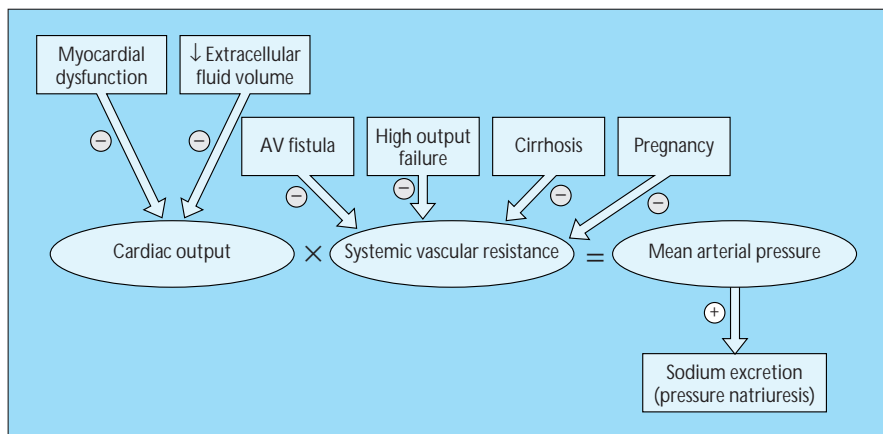
**FIGURE 2-25**

Summary of mechanisms of sodium (Na) retention in volume contraction and in depletion of the “effective” arterial volume. In secondary Na retention, Na retention results primarily

from a reduction in mean arterial pressure (MAP). Some disorders decrease cardiac output, such as congestive heart failure owing to myocardial dysfunction; others decrease systemic vascular resistance, such as high-output cardiac failure, atriovenous fistulas, and cirrhosis. Because MAP is the product of systemic vascular resistance and cardiac output, all causes lead to the same result. As shown in Figures 2-3 and 2-4, small changes in MAP lead to large changes in urinary Na excretion. Although edematous disorders usually are characterized as resulting from contraction of the effective arterial volume, the MAP, as a determinant of renal perfusion pressure, may be the crucial variable (Figs. 2-26 and 2-28 provide supportive data). The mechanisms of edema in nephrotic syndrome are more complex and are discussed in Figures 2-36 to 2-39.

Mechanisms of Extracellular Fluid Volume Expansion in Congestive Heart Failure

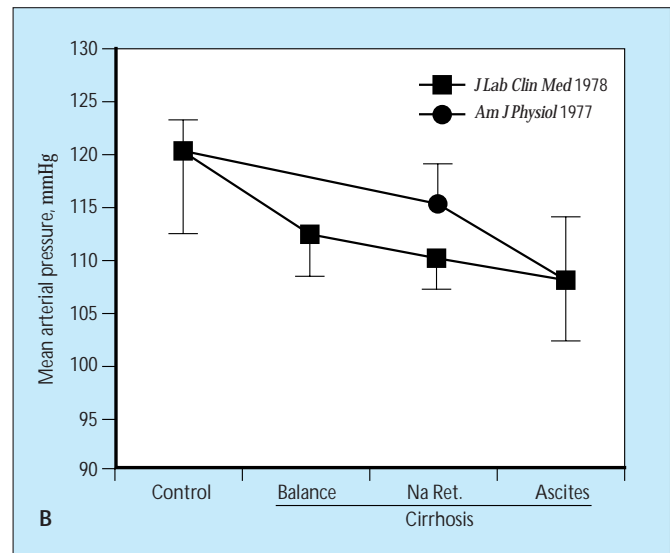
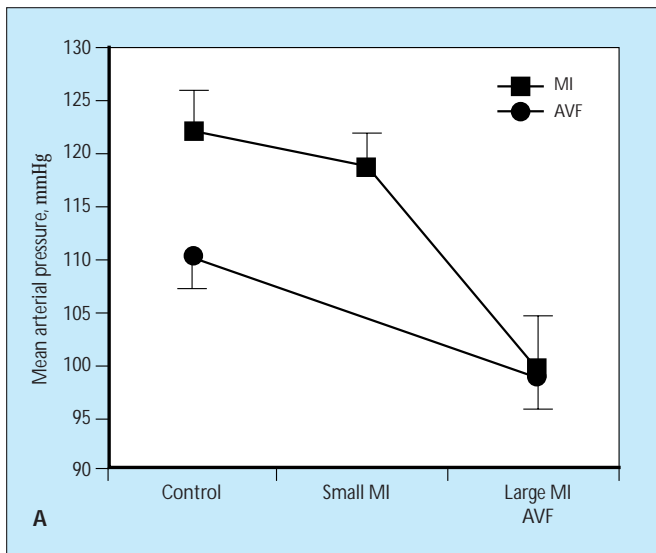

FIGURE 2-26

Role of renal perfusion pressure in sodium (Na) retention. **A**, Results from studies in rats that had undergone myocardial infarction (MI) or placement of an arteriovenous fistula (AVF) [54]. Rats with small and large MIs were identified. Both small and large MIs induced significant Na retention when challenged with Na loads. Renal Na retention occurred in the setting of mild hypotension. AVF also induced significant Na retention, which was associated with a decrease in mean arterial pressure (MAP) [55,56]. Figure 2-3 has shown that Na excretion decreases greatly for each mm Hg decrease in MAP. **B**, Results of two groups of experiments performed by Levy and Allotey [57,58] in

which experimental cirrhosis was induced in dogs by sporadic feeding with dimethylnitrosamine. Three cirrhotic stages were identified based on the pattern of Na retention. In the first, dietary Na intake was balanced by Na excretion. In the second, renal Na retention began, but still without evidence of ascites or edema. In the last, ascites were detected. Because Na was retained before the appearance of ascites, “primary” renal Na retention was inferred. An alternative interpretation of these data suggests that the modest decrease in MAP is responsible for Na retention in this model. Note that in both heart failure and cirrhosis, Na retention correlates with a decline in MAP.

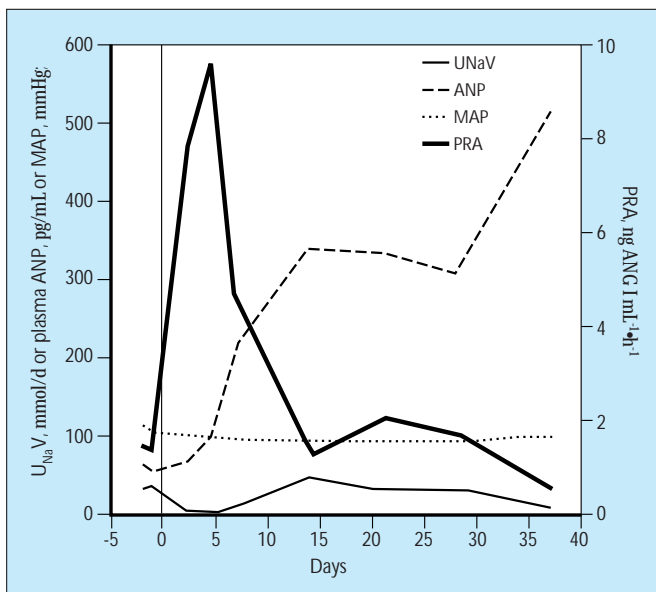

FIGURE 2-27

Mechanism of sodium (Na) retention in high-output cardiac failure. Effects of high-output heart failure induced in dogs by arteriovenous (AV) fistula [59]. After induction of an AV fistula (day 0), plasma renin activity (PRA; thick solid line) increased greatly, correlating temporally with a reduction in urinary Na excretion ($U_{Na}V$; thin solid line). During this period, mean arterial pressure (MAP; dotted line) declined modestly. After day 5, the plasma atrial natriuretic peptide concentration (ANP; dashed line) increased because of volume expansion, returning urinary Na excretion to baseline levels. Thus, Na retention, mediated in part by the renin-angiotensin-aldosterone system, led to volume expansion. The volume expansion suppressed the renin-angiotensin-aldosterone system and stimulated ANP secretion, thereby returning Na excretion to normal. These experiments suggest that ANP secretion plays an important role in maintaining Na excretion in compensated congestive heart failure. This effect of ANP has been confirmed directly in experiments using anti-ANP antibodies [60]. AI—angiotensin I.

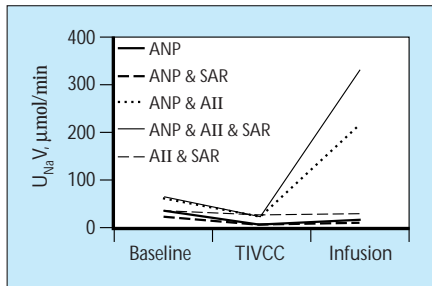

FIGURE 2-28

Mechanism of renal resistance to atrial natriuretic peptide (ANP) in experimental low-output heart failure. Low-output heart failure was induced in dogs by thoracic inferior vena caval constriction (TIVCC), which also led to a significant decrease in renal perfusion pressure (RPP) (from 127 to 120 mm Hg). ANP infusion into dogs with TIVCC did not increase urinary sodium (Na) excretion ($U_{Na}V$, ANP group). In contrast, when the RPP was returned to baseline by infusing angiotensin II (AII), urinary Na excretion increased greatly (ANP + AII). To exclude a direct effect of AII on urinary Na excretion, intrarenal saralasin (SAR) was infused to block renal AII receptors. SAR did not significantly affect the natriuresis induced by ANP plus AII. An independent effect of SAR on urinary Na excretion was excluded by infusing ANP plus SAR and AII plus SAR. These treatments were without effect. These results were interpreted as indicating that the *predominant* cause of resistance to ANP in dogs with low-output congestive heart failure is a reduction in RPP. (Data from Redfield and coworkers [61].)

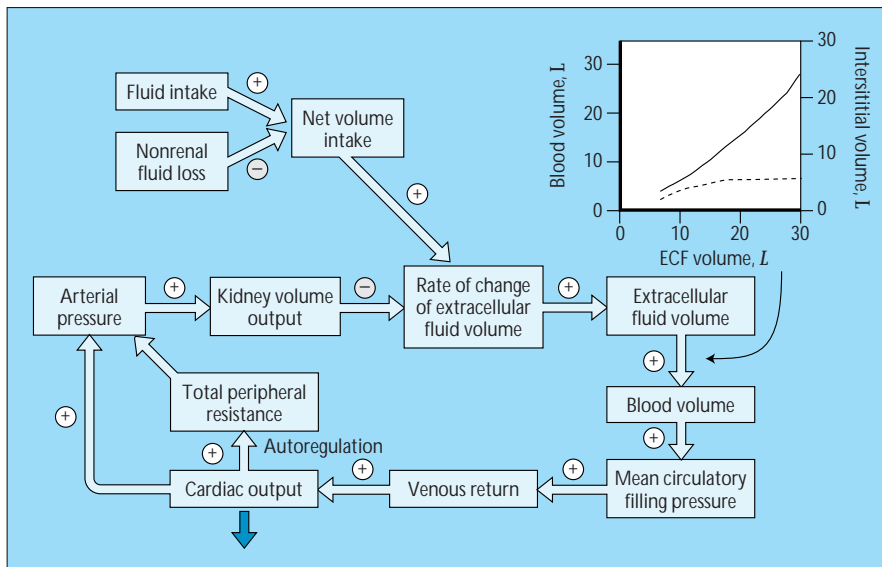

FIGURE 2-29

Mechanism of extracellular fluid (ECF) volume expansion in congestive heart failure. A primary decrease in cardiac output (indicated by dark blue arrow) leads to a decrease in arterial pressure, which decreases pressure natriuresis and volume excretion. These decreases expand the ECF volume. The inset graph shows that the ratio of interstitial volume (solid line) to plasma volume (dotted line) increases as the ECF volume expands because the interstitial compliance increases [62]. Thus, although expansion of the ECF volume increases blood volume and venous return, thereby restoring cardiac output toward normal, this occurs at the expense of a *disproportionate* expansion of interstitial volume, often manifested as edema.

Mechanisms of Extracellular Fluid Volume Expansion in Cirrhosis

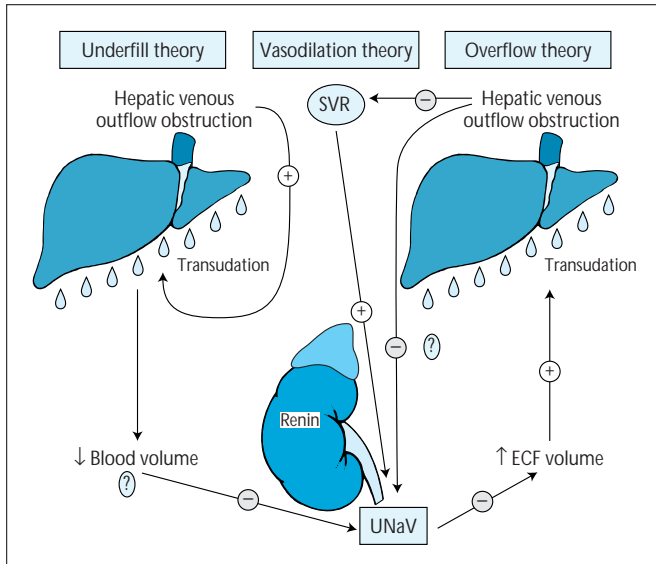

FIGURE 2-30

Three theories of ascites formation in hepatic cirrhosis. Hepatic venous outflow obstruction leads to portal hypertension. According to the *underfill theory*, transudation from the liver leads to reduction of the blood volume, thereby stimulating sodium (Na) retention by the kidney. As indicated by the question mark near the term *blood volume*, a low blood volume is rarely detected in clinical or experimental cirrhosis. Furthermore, this theory predicts that ascites would develop before renal Na retention, when the reverse generally occurs. According to the *overflow theory*, increased portal pressure stimulates renal Na retention through incompletely defined mechanisms. As indicated by the question mark near the arrow from hepatic venous outflow obstruction to U_{NaV} , the nature of the portal hypertension-induced signals for renal Na retention remains unclear. The *vasodilation theory* suggests that portal hypertension leads to vasodilation and relative arterial hypotension. Evidence for vasodilation in cirrhosis that precedes renal Na retention is now convincing, as shown in Figures 2-31 and 2-33 [63].

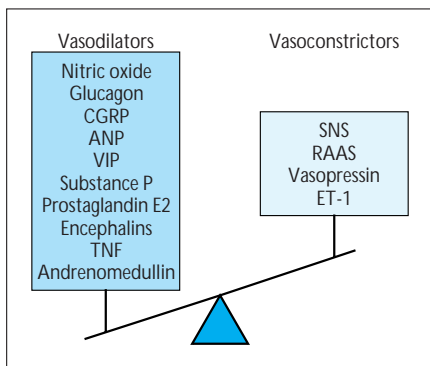

FIGURE 2-31

Alterations in cardiovascular hemodynamics in hepatic cirrhosis. Hepatic dysfunction and portal hypertension increase the production and impair the metabolism of several vasoactive substances. The overall balance of vasoconstriction and vasodilation shifts in favor of dilation. Vasodilation may also shift blood away from the central circulation toward the periphery and away from the kidneys. Some of the vasoactive substances postulated to participate in the hemodynamic disturbances of cirrhosis include those shown here. ANP—atrial natriuretic peptide; ET-1—endothelin-1; CGRP—calcitonin gene related peptide; RAAS—renin/angiotensin/aldosterone system; TNF—tumor necrosis factor; VIP—vasoactive intestinal peptide. (Data from Møller and Henriksen [64].)

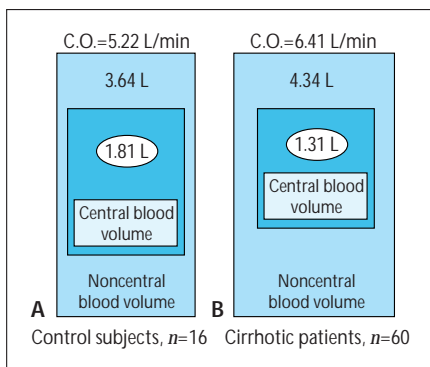

FIGURE 2-32

Effects of cirrhosis on central and noncentral blood volumes. The central blood volume is defined as the blood volume in the heart, lungs, and central arterial tree. Compared with control subjects (A), patients with cirrhosis (B) have decreased central and increased noncentral blood volumes. The higher cardiac output (CO) results from peripheral vasodilation. Perfusion of the kidney is reduced significantly in patients with cirrhosis. (Data from Hillarp and coworkers [65].)

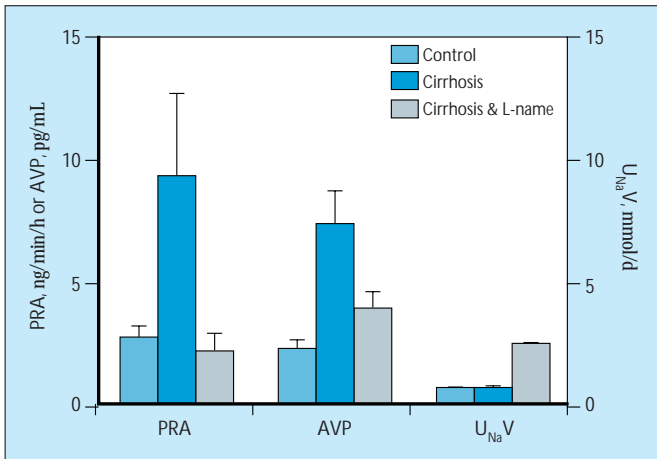

FIGURE 2-33 Contribution of nitric oxide to vasodilation and sodium (Na) retention in cirrhosis. Compared with control rats, rats having cirrhosis induced by carbon tetrachloride and phenobarbital exhibited increased plasma renin activity (PRA) and plasma arginine vasopressin (AVP) concentrations. At steady state, the urinary Na excretion ($U_{Na}V$) was similar in both groups. After treatment with L-NAME for 7 days, plasma renin activity decreased to normal levels, AVP concentrations decreased toward normal levels, and urinary Na excretion increased by threefold. These changes were associated with a normalization of mean arterial pressure and cardiac output. (Data compiled from Niederberger and coworkers [66,67] and Martin and Schrier [68].)

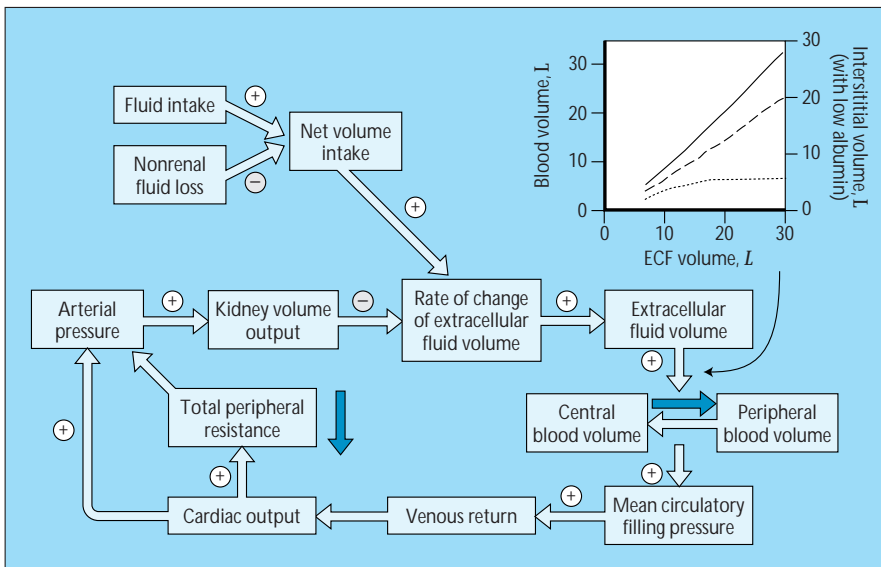

FIGURE 2-34 Mechanisms of sodium (Na) retention in cirrhosis. A primary decrease in systemic vascular resistance (indicated by dark blue arrow), induced by mediators shown in Figure 2-31, leads to a decrease in arterial pressure. The reduction in systemic vascular resistance, however, is not uniform and favors movement of blood from the central (“effective”) circulation into the peripheral circulation, as shown in Figure 2-32. Hypoalbuminemia shifts the interstitial to blood volume ratio upward (compare the interstitial volume with normal [dashed line], and low [solid line], protein levels in the inset graph). Because cardiac output increases and venous return must equal cardiac output, dramatic expansion of the extracellular fluid (ECF) volume occurs.

Mechanisms of Extracellular Fluid Volume Expansion in Nephrotic Syndrome

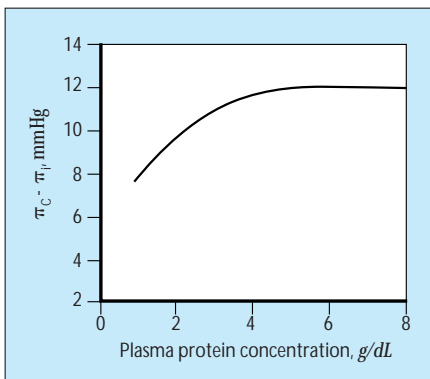

FIGURE 2-35 Changes in plasma protein concentration affect the net oncotic pressure difference across capillaries ($\pi_c - \pi_i$) in humans. Note that moderate reductions in plasma protein concentration have little effect on differences in transcapillary oncotic pressure. Only when plasma protein concentration decreases below 5 g/dL do changes become significant. (Data from Fadnes and coworkers [69].)

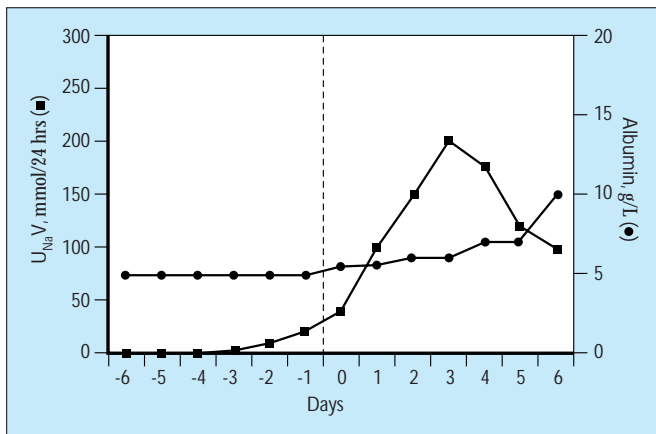

FIGURE 2-36

Time course of recovery from minimal change nephrotic syndrome in five children. Note that urinary Na excretion (squares) increases before serum albumin concentration increases. The data suggest that the natriuresis reflects a change in intrinsic renal Na retention. The data also emphasize that factors other than hypoalbuminemia must contribute to the Na retention that occurs in nephrosis. $U_{Na}V$ —urinary Na excretion volume. (Data from Oliver and Owings [70].)

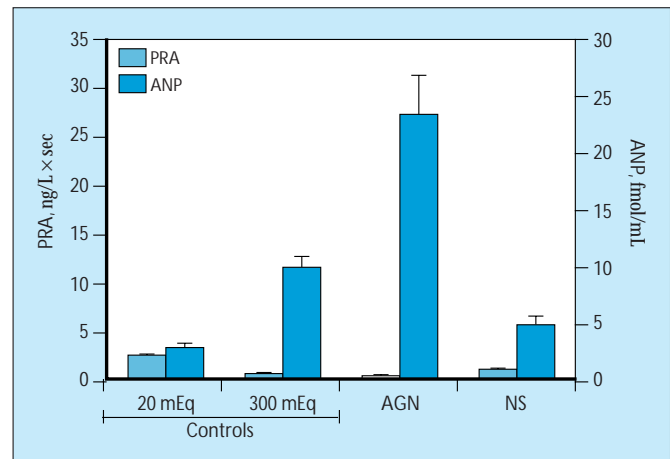

FIGURE 2-37

Plasma renin activity (PRA) and atrial natriuretic peptide (ANP) concentration in the nephrotic syndrome. Shown are PRA and ANP concentration (+standard error) in normal persons ingesting diets high (300 mEq/d) and low (20 mEq/d) in sodium (Na) and in patients with acute glomerulonephritis (AGN), predominantly post-streptococcal, or nephrotic syndrome (NS). Note that PRA is suppressed in patients with AGN to levels below those in normal persons on diets high in Na. PRA suppression suggests that primary renal NaCl retention plays an important role in the pathogenesis of volume expansion in AGN. Although plasma renin activity in nephrotic syndrome is not suppressed to the same degree, the absence of PRA elevation in these patients suggests that primary renal Na retention plays a significant role in the pathogenesis of Na retention in NS as well. (Data from Rodriguez-Iturbe and coworkers [71].)

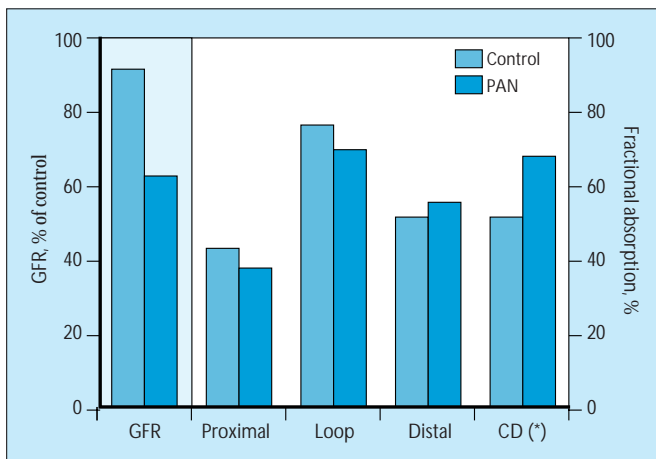

FIGURE 2-38

Sites of sodium (Na) reabsorption along the nephron in control and nephrotic rats (induced by puromycin aminonucleoside [PAN]). The glomerular filtration rates (GFR) in normal and nephrotic rats are shown by the hatched bars. Note the modest reduction in GFR in the nephrotic group, a finding that is common in human nephrosis. Fractional reabsorption rates along the proximal tubule, the loop of Henle, and the superficial distal tubule are indicated. The fractional reabsorption along the collecting duct (CD) is estimated from the difference between the end distal and urine deliveries. The data suggest that the predominant site of increased reabsorption is the collecting duct. Because superficial and deep nephrons may differ in reabsorptive rates, these data would also be consistent with enhanced reabsorption by deep nephrons. Asterisk—data inferred from the difference between distal and urine samples. (Data from Ichikawa and coworkers [72].)

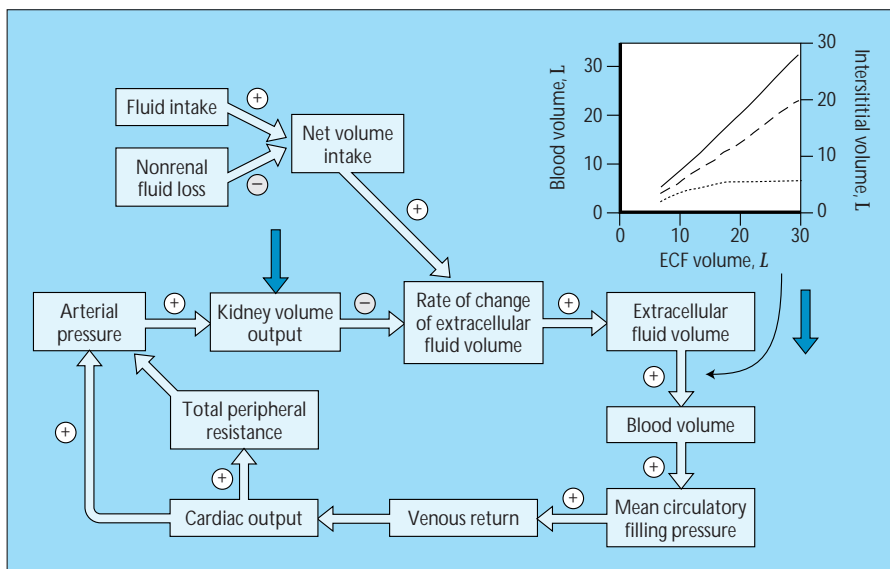

FIGURE 2-39

Mechanisms of extracellular fluid (ECF) volume expansion in nephrotic syndrome. Nephrotic syndrome is characterized by hypoalbuminemia, which shifts the relation between blood and interstitial volume upward (dashed to solid lines in inset). As discussed in Figure 2-35, these effects of hypoalbuminemia are evident when serum albumin concentrations decrease by more than half. In addition, however, hypoalbuminemia may induce vasodilation and arterial hypotension that lead to sodium (Na) retention, independent of transudation of fluid into the interstitium [73,74]. Unlike other states of hypoproteinemia and vasodilation, however, nephrotic syndrome usually is associated with normotension or hypertension. Coupled with the observation made in Figure 2-36 that natriuresis may take place before increases in serum albumin concentration in patients with nephrotic syndrome, these data implicate an important role for primary renal Na retention in this disorder (dark blue arrow). As suggested by Figure 2-37, the decrease in urinary Na excretion may play a larger role in patients with acute glomerulonephritis than in patients with minimal change nephropathy [71].

Extracellular Fluid Volume Homeostasis in Chronic Renal Failure

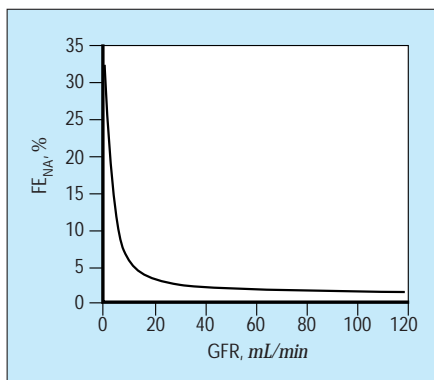

FIGURE 2-40

Relation between glomerular filtration rate (GFR) and fractional sodium (Na) excretion (FE_{Na}). The normal FE_{Na} is less than 1%. Adaptations in chronic renal failure maintain urinary Na excretion equal to dietary intake until end-stage renal disease is reached. To achieve this, the FE_{Na} must increase as the GFR decreases.

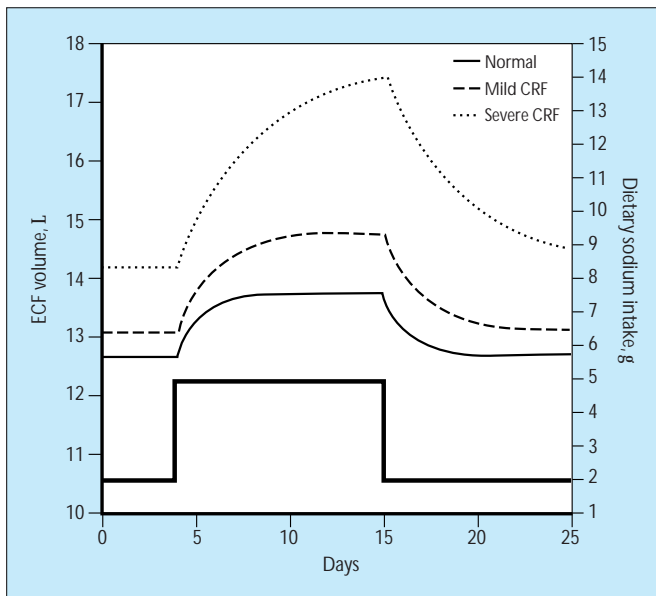

FIGURE 2-41

Effects of dietary sodium (Na) intake on extracellular fluid (ECF) volume in chronic renal failure (CRF) [75]. Compared with normal persons, patients with CRF have expanded ECF volume at normal Na intake. Furthermore, the time necessary to return to neutral balance on shifting from one to another level of Na intake is increased. Thus, whereas urinary Na excretion equals dietary intake of Na within 3 to 5 days in normal persons, this process may take up to 2 weeks in patients with CRF. This time delay means that not only are these patients susceptible to volume overload, but also to volume depletion. This phenomenon can be modeled simply by reducing the time constant (k) given in the equation in Figure 2-2, and leaving the set point (A_0) unchanged. The curves here represent time constants of $0.79 \pm 0.05 \text{ day}^{-1}$ (normal), 0.5 day^{-1} (mild CRF), and 0.25 day^{-1} (severe CRF).

References

- Walser M: Phenomenological analysis of renal regulation of sodium and potassium balance. *Kidney Int* 1985, 27:837–841.
- Simpson FO: Sodium intake, body sodium, and sodium excretion. *Lancet* 1990, 2:25–29.
- Luft FC, Weinberger MH, Grim CE: Sodium sensitivity and resistance in normotensive humans. *Am J Med* 1982, 72:726–736.
- Guyton AC: Blood pressure control: special role of the kidneys and body fluids. *Science* 1991, 252:1813–1816.
- Lassiter WE: Regulation of sodium chloride distribution within the extracellular space. In *The Regulation of Sodium and Chloride Balance*. Edited by Seldin DW, Giebisch G. New York: Raven Press; 1990:23–58.
- Hall JE, Jackson TE: The basic kidney-blood volume-pressure regulatory system: the pressure diuresis and natriuresis phenomena. In *Arterial Pressure and Hypertension*. Edited by Guyton AC. Philadelphia: WB Saunders Co, 1998:87–99.
- Gonzalez-Campoy JM, Knox FG: Integrated responses of the kidney to alterations in extracellular fluid volume. In *The Kidney: Physiology and Pathophysiology*, edn 2. Edited by Seldin DW, Giebisch G. New York: Raven Press; 1992:2041–2097.
- Hall JE, Brands MW: The renin-angiotensin-aldosterone systems. In *The Kidney: Physiology and Pathophysiology*, edn 2. Edited by Seldin DW, Giebisch G. New York: Raven Press; 1992:1455–1504.
- Laragh JH, Sealey JE: The integrated regulation of electrolyte balance and blood pressure by the renin system. In *The Regulation of Sodium and Chloride Balance*. Edited by Seldin DW, Giebisch G. New York: Raven Press, 1990:133–193.
- Obermüller N, Kunchaparty S, Ellison DH, Bachmann S: Expression of the Na-K-2Cl cotransporter by macula densa and thick ascending limb cells of rat and rabbit nephron. *J Clin Invest* 1996, 98:635–640.
- Lapointe J-Y, Bell PD, Cardinal J: Direct evidence for apical Na⁺:2Cl⁻:K⁺ cotransport in macula densa cells. *Am J Physiol* 1990, 258:F1466–F1469.
- Briggs JP: Whys and the wherefores of juxtaglomerular apparatus functions. *Kidney Int* 1996, 49:1724–1726.
- Barajas L: Architecture of the juxtaglomerular apparatus. In *Hypertension: Pathophysiology, Diagnosis and Treatment*. Edited by Laragh JH, Brenner BM. New York: Raven Press; 1990:XX–XX.
- Skott O, Briggs JP: Direct demonstration of macula densa mediated renin secretion. *Science* 1987, 237:1618–1620.
- Hall JE, Guyton AC: Changes in renal hemodynamics and renin release caused by increased plasma oncotic pressure. *Am J Physiol* 1976, 231:1550.
- Bachmann S, Bosse HM, Mundel P: Topography of nitric oxide synthesis by localizing constitutive NO synthetases in mammalian kidney. *Am J Physiol* 1995, 268:F885–F898.
- Johnson RA, Freeman RH: Renin release in rats during blockade of nitric oxide synthesis. *Am J Physiol* 1994, 266:R1723–R1729.
- Schricker K, Hegyi I, Hamann M, et al.: Tonic stimulation of renin gene expression by nitric oxide is counteracted by tonic inhibition through angiotensin II. *Proc Natl Acad Sci USA* 1995, 92:8006–8010.
- Funder JW: Mineralocorticoids, glucocorticoids, receptors and response elements. *Science* 1993, 259:1132–1133.
- Náray-Fejes-Tóth A, Fejes-Tóth G: Glucocorticoid receptors mediate mineralocorticoid-like effects in cultured collecting duct cells. *Am J Physiol Renal Fluid Electrolyte Physiol* 1990, 259:F672–F678.
- Mune T, Rogerson FM, Nikkila H, et al.: Human hypertension caused by mutations in the kidney isozyme of 11 β -hydroxysteroid dehydrogenase. *Nature Genet* 1995, 10:394–399.
- Hollander W, Judson WE: The relationship of cardiovascular and renal hemodynamic function to sodium excretion in patients with severe heart disease but without edema. *J Clin Invest* 1956, 35:970–979.
- Brenner BM, Ballermann BJ, Gunning ME, Zeidel ML: Diverse biological actions of atrial natriuretic peptide. *Physiol Rev* 1990, 70:665–700.

24. Kishimoto I, Dubois SK, Garbers DL: The heart communicates with the kidney exclusively through the guanylyl cyclase-A receptor: Acute handling of sodium and water in response to volume expansion. *Proc Natl Acad Sci USA* 1996, 93:6215–6219.
25. Korner PI: Integrative neural cardiovascular control. *Physiol Rev* 1971, 51:312–367.
26. Cogan MG: Neurogenic regulation of proximal bicarbonate and chloride reabsorption. *Am J Physiol* 1986, 250:F22–F26.
27. Geibel J, Giebisch G, Boron WF: Angiotensin II stimulates both Na⁺-H⁺ exchange and Na⁺/HCO₃⁻ cotransport in the rabbit proximal tubule. *Proc Natl Acad Sci USA* 1990, 87:7917–7920.
28. Block RD, Zikos D, Fisher KA, et al.: Peterson DR: Activation of proximal tubular Na⁺-H⁺ exchanger by angiotensin II. *Am J Physiol* 1992, 263:F135–F143.
29. Bertorello A, Aperia A: Regulation of Na⁺-K⁺-ATPase activity in kidney proximal tubules: involvement of GTP binding proteins. *Am J Physiol* 1989, 256:F57–F62.
30. Aperia AC: Regulation of sodium transport. *Curr Opin Nephrol Hypertens* 1995, 4:416–420.
31. Bouby N, Bankir L, Trinh-Trang-Tan MM, et al.: Selective ADH-induced hypertrophy of the medullary thick ascending limb in Brattleboro rats. *Kidney Int* 1985, 28:456–466.
32. Chabardès D, Gagnan-Brunette M, Imbert-Tébol M: Adenylate cyclase responsiveness to hormones in various portions of the human nephron. *J Clin Invest* 1980, 65:439–448.
33. Stokes JB: Effects of prostaglandin E₂ on chloride transport across the rabbit thick ascending limb of Henle. *J Clin Invest* 1979, 64:495–502.
34. Escalante B, Erijl D, Falck JR, McGiff JC: Effect of cytochrome P450 arachidonate metabolites on ion transport in rabbit kidney loop of Henle. *Science* 1991, 251:799–802.
35. Amlal H, Legoff C, Vernimmen C, et al.: Na(+)-K+(NH4+)-2Cl- cotransport in medullary thick ascending limb: control by PKA, PKC, and 20-HETE. *Am J Physiol* 1996, 271:C455–C463.
36. Culpepper RM, Adreoli TE: Interactions among prostaglandin E₂, antidiuretic hormone and cyclic adenosine monophosphate in modulating Cl⁻ absorption in single mouse medullary thick ascending limbs of Henle. *J Clin Invest* 1983, 71:1588–1601.
37. Ecelbarger CA, Terris J, Hoyer JR, et al.: Localization and regulation of the rat renal Na⁺-K⁺-2Cl⁻ cotransporter. BSC-1. *Am J Physiol Renal Fluid Electrolyte Physiol* 1996, 271:F619–F628.
38. Chen Z, Vaughn DA, Blakeley P, Fanestil DD: Adrenocortical steroids increase renal thiazide diuretic receptor density and response. *J Am Soc Nephrol* 1994, 5:1361–1368.
39. Velázquez H, Bartiss A, Bernstein PL, Ellison DH: Adrenal steroids stimulate thiazide-sensitive NaCl transport by the rat renal distal tubule. *Am J Physiol* 1996, 39:F211–F219.
40. Wang T, Giebisch G: Effects of angiotensin II on electrolyte transport in the early and late distal tubule in rat kidney. *Am J Physiol Renal Fluid Electrolyte Physiol* 1996, 271:F143–F149.
41. Wang T, Chan YL: Neural control of distal tubular bicarbonate and fluid transport. *Am J Physiol* 1989, 257:F72–F76.
42. Bencsáth P, Szénási G, Takács L: Water and electrolyte transport in Henle's loop and distal tubule after renal sympathectomy in the rat. *Am J Physiol* 1985, 249:F308–F314.
43. Rossier BC, Palmer LG: Mechanisms of aldosterone action on sodium and potassium transport. In *The Kidney: Physiology and Pathophysiology*, edn 2. Edited by Seldin DW, Giebisch G. New York: Raven Press, 1992:1373–1409.
44. Breyer MD, Ando Y: Hormonal signalling and regulation of salt and water transport in the collecting duct. *Ann Rev Physiol* 1994, 56:711–739.
45. Schafer JA, Hawk CT: Regulation of Na⁺ channels in the cortical collecting duct by AVP and mineralocorticoids. *Int Kidney* 1992, 41:255–268.
46. Kudo LH, Van Baak AA, Rocha AS: Effects of vasopressin on sodium transport across inner medullary collecting duct. *Am J Physiol* 1990, 258:F1438–F1447.
47. Nielsen S, Chou C-L, Marples D, et al.: Vasopressin increases water permeability of kidney collecting duct by inducing translocation of aquaporin: CD water channels to plasma membrane. *Proc Natl Acad Sci USA* 1995, 92:1013–1017.
48. Schafer JA: Salt and water homeostasis: Is it just a matter of good bookkeeping? *J Am Soc Nephrol* 1994, 4:1933–1950.
49. Husted RF, Laplace JR, Stokes JB: Enhancement of electrogenic Na⁺ transport across rat inner medullary collecting duct cells in culture. *J Clin Invest* 1990, 86:498–506.
50. Zeidel ML, Jabs K, Kikeri D, Silva P: Kinins inhibit conductive Na⁺ uptake by rabbit inner medullary collecting duct cells. *Am J Physiol Renal Fluid Electrolyte Physiol* 1990, 258:F1584–F1591.
51. Zeidel ML: Hormonal regulation of inner medullary collecting duct sodium transport. *Am J Physiol Renal Fluid Electrolyte Physiol* 1993, 265:F159–F173.
52. Light DB, Ausiello DA, Stanton BA: Guanine nucleotide-binding protein, α_{i-3}, directly activates a cation channel in rat renal inner medullary collecting duct cells. *J Clin Invest* 1989, 84:352–356.
53. Light DB, Schwiebert EM, Karlson KH, Stanton BA: Atrial natriuretic peptide inhibits a cation channel in renal inner medullary collecting duct cells. *Science* 1989, 243:383–385.
54. Hostetter TH, Pfeffer JM, Pfeffer MA, et al.: Cardiorenal hemodynamics and sodium excretion in rats with myocardial dysfunction. *Am J Physiol* 1983, 245:H98–H103.
55. Villarreal D, Freeman RH, Brands MW: DOCA administration and atrial natriuretic factor in dogs with chronic heart failure. *Am J Physiol* 1989, 257:H739–H745.
56. Villarreal D, Freeman RH, Davis JO, et al.: Atrial natriuretic factor secretion in dogs with experimental high-output heart failure. *Am J Physiol* 1987, 252:H692–H696.
57. Levy M, Allotey JBK: Temporal relationships between urinary salt retention and altered systemic hemodynamics in dogs with experimental cirrhosis. *J Lab Clin Med* 1978, 92:560–569.
58. Levy M: Sodium retention and ascites formation in dogs with experimental portal cirrhosis. *Am J Physiol* 1977, 233:F572–F585.
59. Villarreal D, Freeman RH, Johnson RA: Neurohumoral modulators and sodium balance in experimental heart failure. *Am J Physiol Heart Circ Physiol* 1993, 264:H1187–H1193.
60. Awazu M, Ichikawa I: Alterations in renal function in experimental congestive heart failure. *Sem Nephrology* 1994, 14:401–411.
61. Redfield MM, Edwards BS, Heublein DM, Burnett JC Jr: Restoration of renal response to atrial natriuretic factor in experimental low-output heart failure. *Am J Physiol* 1989, 257:R917–R923.
62. Manning RD Jr, Coleman TG, Samar RE: Autoregulation, cardiac output, total peripheral resistance and the “quantitative cascade” of the kidney-blood volume system for pressure control. In *Arterial Pressure and Hypertension*. Edited by Guyton AC. Philadelphia: WB Saunders Co; 1980:139–155.
63. Albillos A, Colombato LA, Groszmann RJ: Vasodilation and sodium retention in prehepatic portal hypertension. *Gastroenterology* 1992, 102:931–935.
64. Møller S, Henriksen JH: Circulatory abnormalities in cirrhosis with focus on neurohumoral aspects. *Sem Nephrol* 1997, 17:505–519.
65. Hillarp A, Zöller B, Dahlbäck M: Activated protein C resistance as a basis for venous thrombosis. *Am J Med* 1996, 101:534–540.
66. Niederberger M, Martin P-Y, Ginès P, et al.: Normalization of nitric oxide production corrects arterial vasodilation and hyperdynamic circulation in cirrhotic rats. *Gastroenterology* 1995, 109:1624–1630.

67. Niederberger M, Ginès P, Tsai P, *et al.*: Increased aortic cyclic guanosine monophosphate concentration in experimental cirrhosis in rats: evidence for a role of nitric oxide in the pathogenesis of arterial vasodilation in cirrhosis. *Hepatology* 1995, 21:1625–1631.
68. Martin P-Y, Schrier RW: Pathogenesis of water and sodium retention in cirrhosis. *Kidney Int* 1997, 51(suppl 59):S-43–S-49.
69. Fadnes HO, Pape JF, Sundsfjord JA: A study on oedema mechanism in nephrotic syndrome. *Scand J Clin Lab Invest* 1986, 46:533–538.
70. Oliver WJ, Owings CL: Sodium excretion in the nephrotic syndrome: relation to serum albumin concentration, glomerular filtration rate, and aldosterone secretion rate. *Am J Dis Child* 1967, 113:352–362.
71. Rodríguez-Iturbe B, Colic D, Parra G, Gutkowska J: Atrial natriuretic factor in the acute nephritic and nephrotic syndromes. *Kidney Int* 1990, 38:512–517.
72. Ichikawa I, Rennke HG, Hoyer JR, *et al.*: Role for intrarenal mechanisms in the impaired salt excretion of experimental nephrotic syndrome. *J Clin Invest* 1983, 71:91–103.
73. Manning RD Jr: Effects of hypoproteinemia on renal hemodynamics, arterial pressure, and fluid volume. *Am J Physiol* 1997, 252:F91–F98.
74. Manning RD Jr, Guyton AC: Effects of hypoproteinemia on fluid volumes and arterial pressure. *Am J Physiol* 1983, 245:H284–H293.
75. Mitch WE, Wilcox CS: Disorders of body fluids, sodium and potassium in chronic renal failure. *Am J Med* 1982, 72:536–550.